

## FCM TAB PULL PRICING ALWAYS SHIP SAME DAY

### FCM P-15 -TAB PULL (3/4 x 1-1/2" SOLID BRONZE ANGLE STOCK)

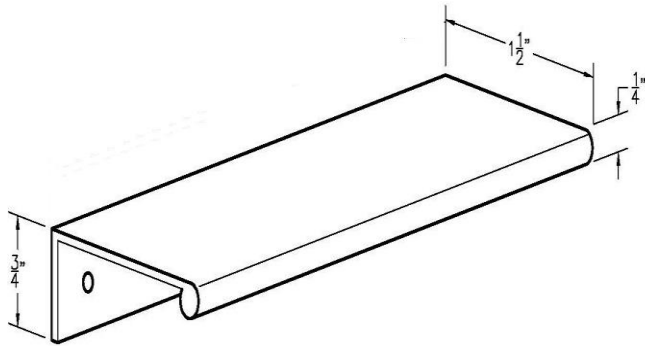

FINISHED ON ALL SIDES SPEC'S ON LAST PAGE

MATTE BLACK / SATIN CHROME  
POLISH CHROME

MATTE BLACK / SATIN CHROME  
POLISH CHROME

MATTE BLACK / SATIN  
CHROME/ POLISH CHROME

MATTE BLACK / SATIN CHROME  
POLISH CHROME

SATIN NICKEL  
POLISH BRASS / SATIN BRASS

SATIN NICKEL  
POLISH BRASS / SATIN BRASS

SATIN NICKEL  
POLISH BRASS / SATIN BRASS

SATIN NICKEL  
POLISH BRASS / SATIN BRASS

PART NUMBER	Overall Length	Hole Location CTC	C/S Holes	Depth	1-99	100-499	500-999	1000+	1-99	100-499	500-999	1000+
<b>FCM-P-15-ET</b>	1-1/4"	5/8"	2	1-1/2"	8.20	8.10	8.00	7.50	11.30	10.90	10.59	10.20
<b>FCM-P-15-T</b>	1-1/2"	3/4"	2	1-1/2"	8.40	8.30	8.20	7.85	12.80	12.73	12.60	12.20
<b>FCM-P-15-S</b>	2"	11/16"	2	1-1/2"	9.99	9.85	9.70	9.60	13.50	13.40	13.30	13.00
<b>FCM-P-15-M</b>	3"	2"	2	1-1/2"	11.40	11.10	10.99	10.60	14.70	14.20	14.00	13.50
<b>FCM-P-15-L</b>	4"	3"	2	1-1/2"	12.59	12.15	12.02	11.75	15.10	14.60	14.40	13.80

MEDIUM ANTIQUE BRONZE AND POLISHED BLACK NICKEL ON NEXT PAGE

**FCM P-15 -TAB PULL  
(3/4 x 1-1/2" SOLID BRONZE ANGLE STOCK)**

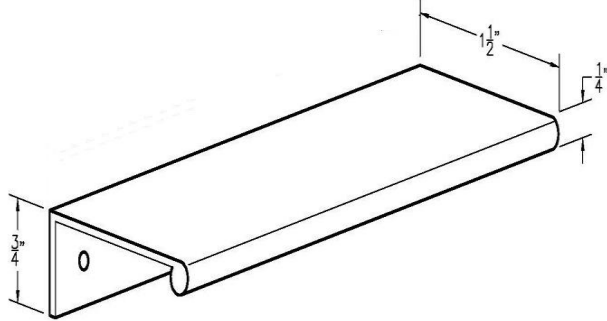

FINISHED ON ALL SIDES SPEC'S ON LAST PAGE

**MEDIUM ANTIQUE BRONZE**

**MEDIUM ANTIQUE BRONZE**

**MEDIUM ANTIQUE BRONZE**

**MEDIUM ANTIQUE BRONZE**

**BLACK CHROME**

**BLACK CHROME**

**BLACK CHROME**

**BLACK CHROME**

PART NUMBER	Overall Length	Hole Location CTC	C/S Holes	Depth	1-99	100-499	500-999	1000+	1-99	100-499	500-999	1000+
<b>FCM-P-15-ET</b>	1-1/4"	5/8"	2	1-1/2"	11.85	11.50	11.20	11.00	12.20	12.10	11.85	11.10
<b>FCM-P-15-T</b>	1-1/2"	3/4"	2	1-1/2"	12.50	12.30	12.00	11.00	13.50	13.30	13.00	12.00
<b>FCM-P-15-S</b>	2"	11/16"	2	1-1/2"	14.50	14.00	13.75	13.00	14.50	14.00	13.50	13.00
<b>FCM-P-15-M</b>	3"	2"	2	1-1/2"	16.00	15.60	15.20	14.80	15.20	15.20	14.65	14.20
<b>FCM-P-15-L</b>	4"	3"	2	1-1/2"	15.30	15.10	15.00	14.00	16.00	15.20	15.00	14.00

Tolerance +/- 1/16"

**ADDITIONAL SIZES NEXT PAGE**

Fantasy Creations in Metal Ph-951.280.0438 Metalsdiva@FCMetals.com www.FCMetals.com

**FCM P-15 -TAB PULL  
(3/4 x 1-1/2" SOLID BRONZE ANGLE STOCK)**

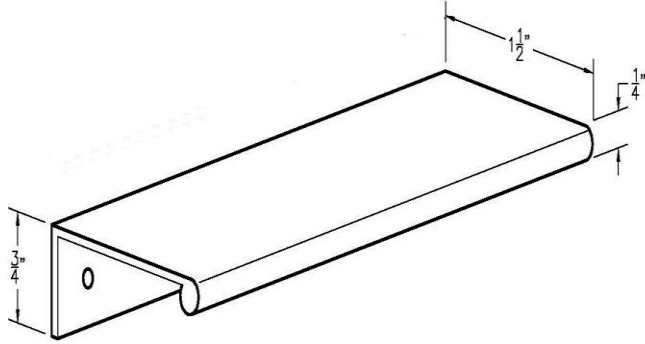

FINISHED ON ALL SIDES SPEC'S ON LAST PAGE

MATTE BLACK / SATIN CHROME  
POLISH CHROME

MATTE BLACK / SATIN CHROME  
POLISH CHROME

MATTE BLACK / SATIN CHROME  
POLISH CHROME

MATTE BLACK / SATIN CHROME  
POLISH CHROME

SATIN NICKEL  
POLISH BRASS / SATIN BRASS

SATIN NICKEL  
POLISH BRASS / SATIN BRASS

SATIN NICKEL  
POLISH BRASS / SATIN BRASS

SATIN NICKEL  
POLISH BRASS / SATIN BRASS

PART NUMBER	Overall Length	Hole Location CTC	C/S Holes	Depth								
					1-99	100-499	500-999	1000+	1-99	100-499	500-999	1000+
<b>FCM-P-15-G</b>	6"	5"	2	1-1/2"	18.30	17.10	17.00	16.40	21.20	21.00	19.50	19.00
<b>FCM-P-15-GM</b>	8"	3"	3	1-1/2"	26.40	26.00	25.25	24.25	34.24	34.00	33.00	32.00
<b>FCM-P-15-GL</b>	10"	4"	3	1-1/2"	35.20	35.00	34.00	33.00	45.00	44.25	43.10	42.00
<b>FCM-P-15-SG</b>	12"	3-5/16"	4	1-1/2"	44.00	43.50	42.10	40.50	54.00	53.20	52.00	50.00

MEDIUM ANTIQUE BRONZE AND POLISHED BLACK NICKEL ON NEXT PAGE

Fantasy Creations in Metal Ph-951.280.0438 Metalsdiva@FCMetals.com www.FCMetals.com

**FCM P-15 -TAB PULL**  
**(3/4 x 1-1/2" SOLID BRONZE ANGLE STOCK)**

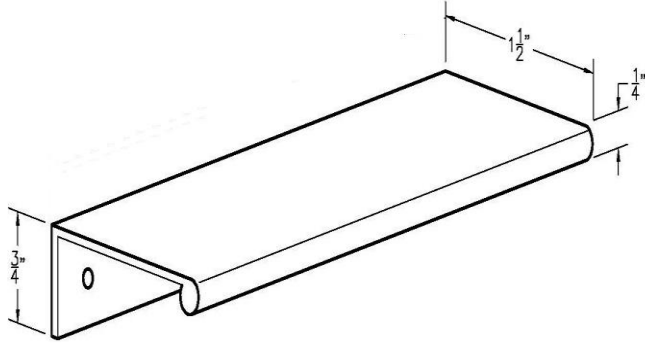

FINISHED ON ALL SIDES SPEC'S ON LAST PAGE

MEDIUM ANTIQUE BRONZE

MEDIUM ANTIQUE BRONZE

MEDIUM ANTIQUE BRONZE

MEDIUM ANTIQUE BRONZE

POLISH BLACK CHROME

POLISH BLACK CHROME

POLISH BLACK CHROME

POLISH BLACK CHROME

PART NUMBER	Overall Length	Hole Location CTC	C/S Holes	Depth	1-99	100-499	500-999	1000+	1-99	100-499	500-999	1000+
<b>FCM-P-15-G</b>	6	5"	2	1-1/2"	32.00	31.50	30.10	29.00	32.00	32.00	31.00	29.00
<b>FCM-P-15-GM</b>	8	3"	3	1-1/2"	38.00	37.00	36.00	35.00	34.50	34.00	33.00	32.00
<b>FCM-P-15-GL</b>	10	4"	3	1-1/2"	47.00	45.75	44.00	43.00	45.50	44.20	43.00	42.00
<b>FCM-P-15-SG</b>	12	3-5/16"	4	1-1/2"	54.00	53.00	51.00	50.00	54.00	53.00	52.00	50.00

Tolerance +/- 1/16"

ADDITIONAL SIZES NEXT PAGE

Fantasy Creations in Metal Ph-951.280.0438 Metalsdiva@FCMetals.com www.FCMetals.com

**FCM P-15 -TAB PULL  
(3/4 x 1-1/2" SOLID BRONZE ANGLE STOCK)**

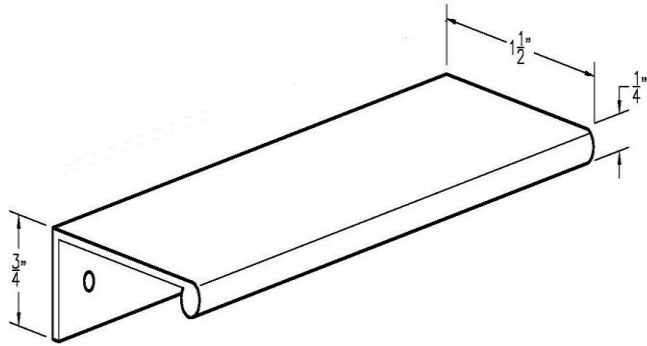

FINISHED ON ALL SIDES SPEC'S ON LAST PAGE

MATTE BLACK

MATTE BLACK

MATTE BLACK

MATTE BLACK

SATIN CHROME/POLISH CHROME  
SATIN NICKEL

SATIN CHROME/POLISH CHROME  
SATIN NICKEL

SATIN CHROME/POLISH CHROME  
SATIN NICKEL

SATIN CHROME/POLISH CHROME  
SATIN NICKEL

PART NUMBER	Overall Length	Hole Location CTC	C/S Holes	Depth	1-99	100-499	500-999	1000+	1-99	100-499	500-999	1000+
<b>FCM-P-15-14</b>	14"	4"	4	1-1/2"	43.00	42.00	41.00	40.00	56.00	55.00	54.00	52.00
<b>FCM-P-15-16</b>	16"	4-21/32"	4	1-1/2"	45.00	44.00	43.00	42.00	65.00	63.00	62.00	60.00
<b>FCM-P-15-18</b>	18"	5-11/32"	4	1-1/2"	45.00	44.00	43.00	42.00	72.50	71.00	69.00	67.00
<b>FCM-P-15-20</b>	20"	6"	4	1-1/2"	46.00	45.00	44.00	43.00	82.80	80.00	78.00	77.00
<b>FCM-P-15-22</b>	22"	6-21/32"	4	1-1/2"	47.00	46.00	45.00	44.00	88.00	86.00	84.00	80.00
<b>FCM-P-15-24</b>	24"	7-11/32"	4	1-1/2"	48.00	47.00	46.00	45.00	98.00	97.00	96.00	94.00

Tolerance +/- 1/16"

FINISHED ON 'ALL SIDES'  
ON FOLLOWING PAGE

Fantasy Creations in Metal Ph-951.280.0438 Metalsdiva@FCMetals.com www.FCMetals.com  
**ALWAYS IN STOCK AND READY TO SHIP SAME DAY.**

**Our FCM-P-15 Tab Pull is our Most Popular Pull.** Extruded out of Solid Bronze for a clean smooth surface, we polish and plate or powder coat in any finish you require. Our standard finishes are based on the most popular requests, but any custom finish can be achieved on this quality material.

Custom sizes are also available up to 8 feet long. Please call us for any special request you may have. We are here and always eager to help!

**SIZES BELOW ARE ON THE SHELF, FINISHED ON ALL SIDES (AS), AND READY TO SHIP.  
WE CAN FINISH ANY ADDITIONAL SIZES YOU NEED, ON ALL SIDES, INCLUDING YOUR CUSTOM SIZE REQUIREMENTS.**

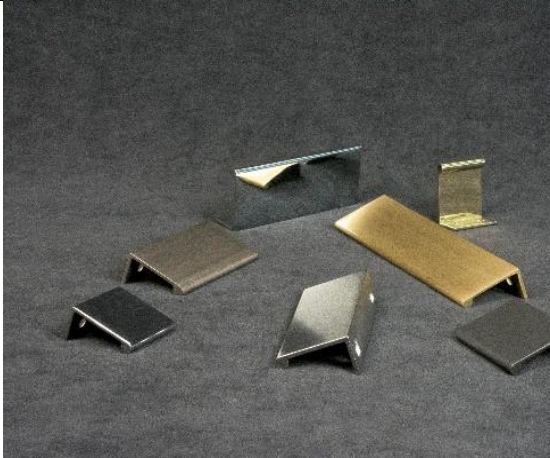
<b>FINISHED 'AS' = ALL SIDES</b> Standard Finishes					<b>MATTE BLACK / SATIN CHROME POLISH CHROME</b>	<b>MATTE BLACK / SATIN CHROME POLISH CHROME</b>	<b>MATTE BLACK / SATIN CHROME POLISH CHROME</b>	<b>MATTE BLACK / SATIN CHROME POLISH CHROME</b>	<b>SATIN NICKEL</b>	<b>SATIN NICKEL</b>	<b>SATIN NICKEL</b>	<b>SATIN NICKEL</b>
	<b>Part Number</b>	<b>Overall Length</b>	<b>Hole Location CTC</b>	<b>C/S Holes</b>	<b>Depth</b>	1-99	100-499	500-999	1000+	1-99	100-499	500-999
<b>FCM-P-15-ET-AS (All Sides)</b>	1-1/4"	5/8"	2	1-1/2"	12.00	11.45	11.30	12.00	13.70	13.00	12.40	12.00
<b>FCM-P-15-M-AS (All Sides)</b>	3"	2"	2	1-1/2"	15.65	15.40	15.20	14.70	18.25	17.80	17.20	17.00
<b>FCM-P-15-L-AS (All Sides)</b>	4"	3"	2	1-1/2"	18.29	17.00	16.35	16.00	22.85	21.20	19.88	18.45
<b>FCM-P-15-G-AS (All Sides)</b>	6"	5"	2	1-1/2"	24.99	24.25	23.10	22.60	30.50	30.00	29.50	28.00

Tolerance +/- 1/16

Fantasy Creations in Metal    Ph-951.280.0438    Metalsdiva@FCMetals.com    www.FCMetals.com

**ALWAYS IN STOCK AND READY TO SHIP SAME DAY.**

**Our FCM-P-15 Tab Pull Is Our Most Popular Pull.** Extruded out of Solid Bronze for a clean smooth surface, we polish and plate or powder coat in any finish you require. Our standard finishes are based on the most popular requests, but any custom finish can be achieved on this quality material.

Custom sizes are also available up to 8 feet long. Please call us for any special request you may have. We are here and always eager to help!

**SEE OUR BEAUTIFUL PULLS ON NEXT TWO PAGES.**

Fantasy Creations in Metal Ph-951.280.0438 Metalsdiva@FCMetals.com www.FCMetals.com

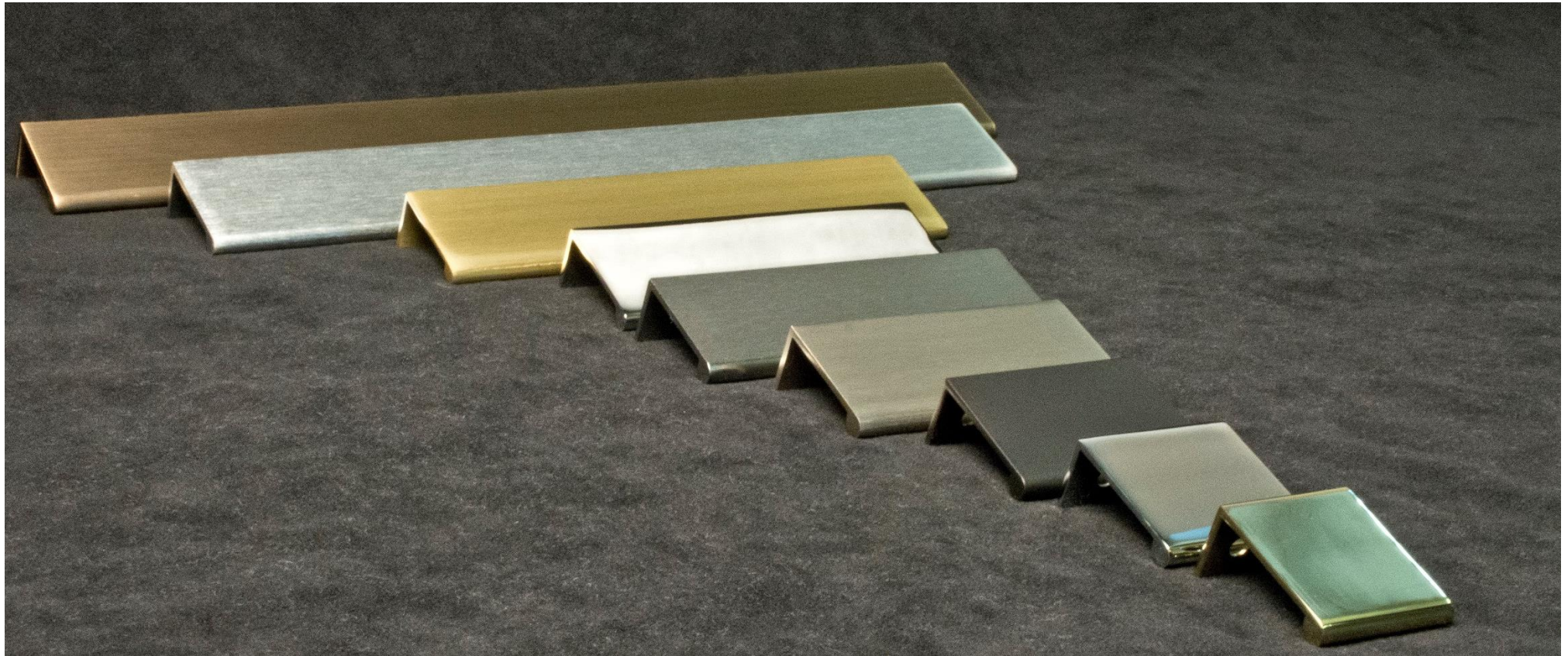

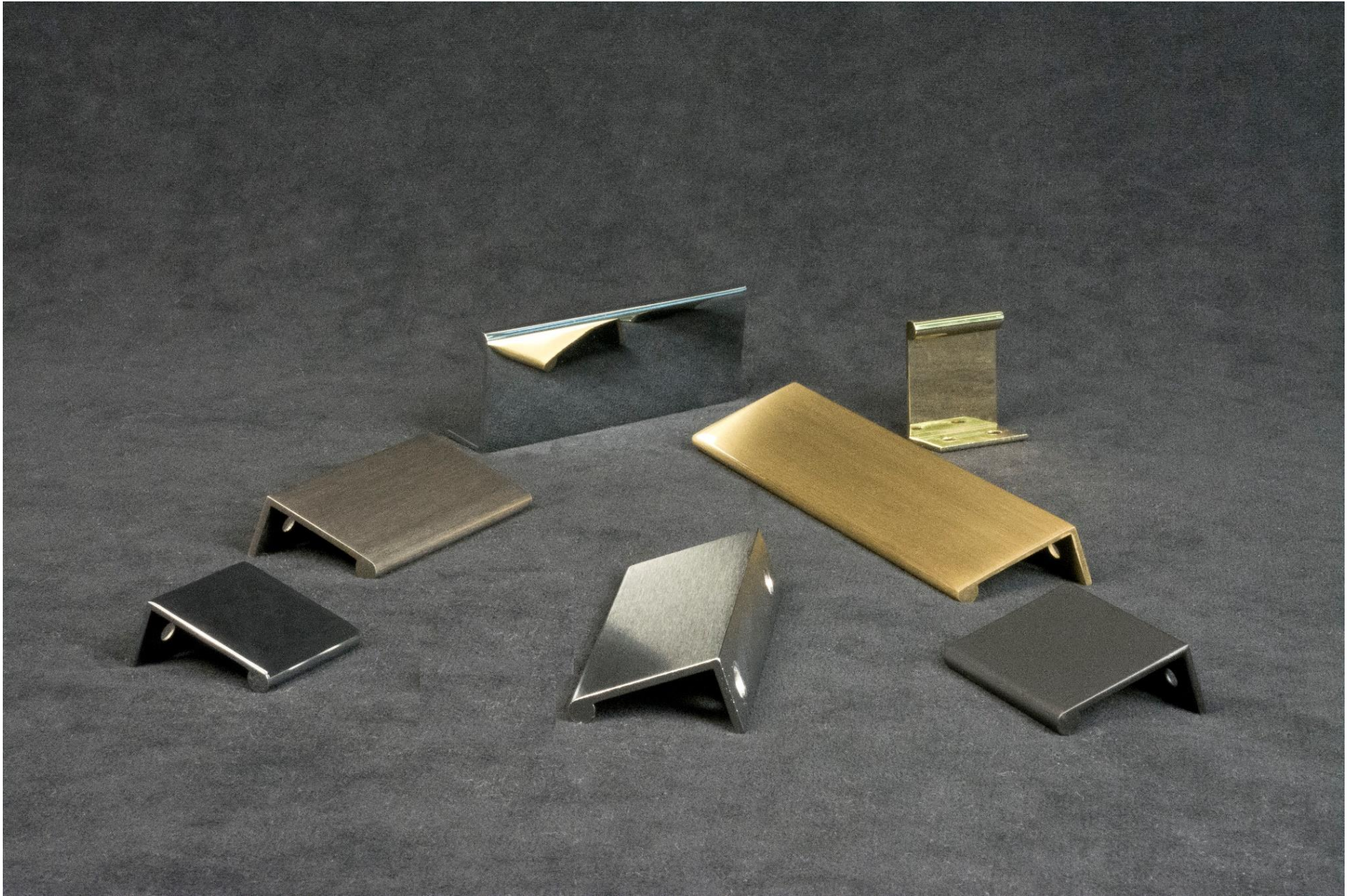

Fantasy Creations in Metal Ph-951.280.0438 Metalsdiva@FCMetals.com www.FCMetals.com



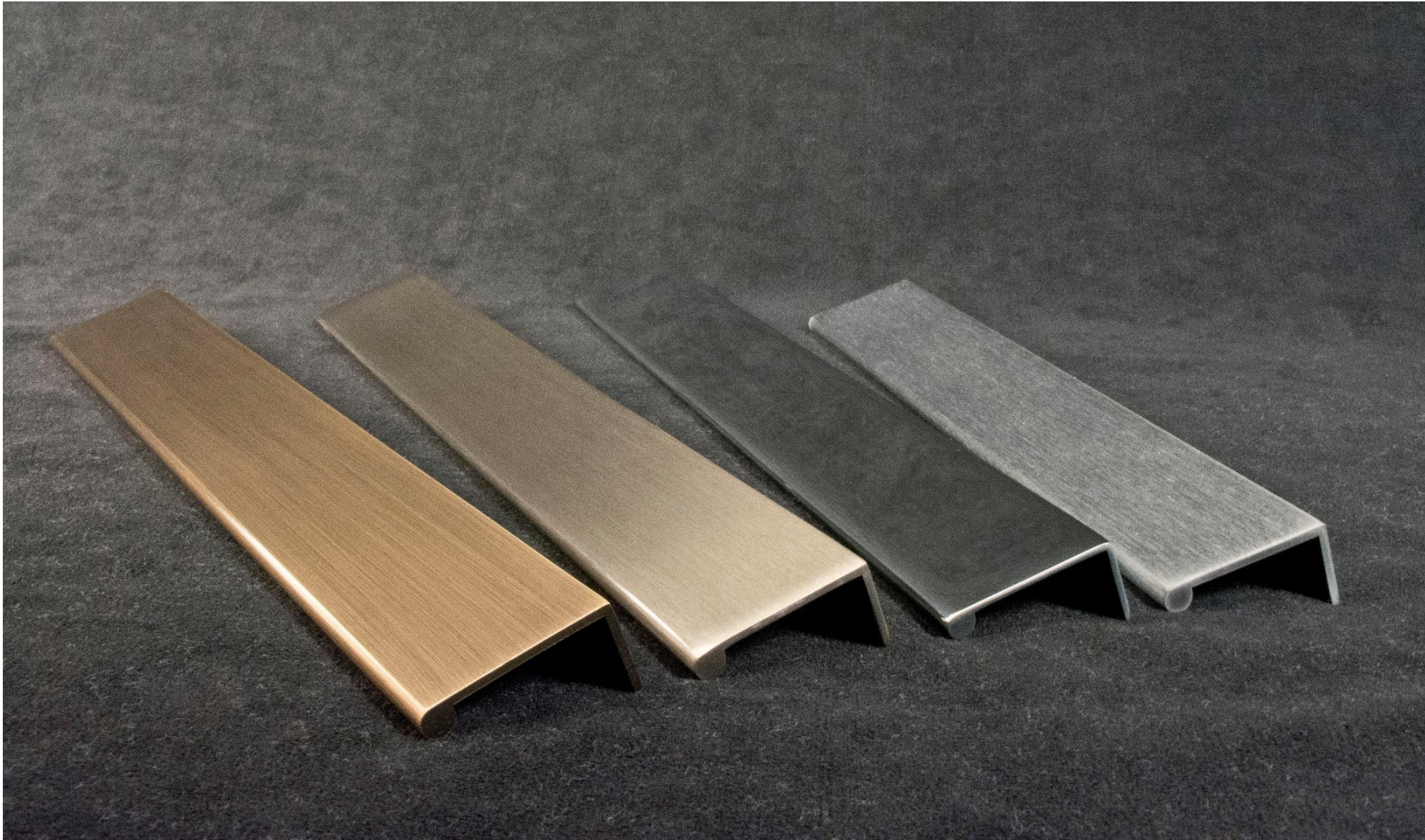

Fantasy Creations in Metal Ph-951.280.0438 Metalsdiva@FCMetals.com www.FCMetals.com

Updated 5.9.22